

I B.TECH - EXAMINATIONS - MAY, 2011
CLASSICAL MECHANICS
 (COMMON TO MECHANICAL ENGINEERING, CHEMICAL ENGINEERING &
 MECHATRONICS)

Time: 3hours

Max. Marks: 80

Answer any FIVE questions
All Questions Carry Equal Marks

- - -

- 1.a) Distinguish between co-planar and non-co planar forces. Classify the various types of forces.
- b) AD is a string hung from a horizontal ceiling at A and D. A weight of 75 N is hung from point B. Determine the magnitude of weight that should be hung from point C such that the portion BC of the string is horizontal. Also determine the tension in various portions AB, BC and CD of the string as shown in figure 1.

[6+10]

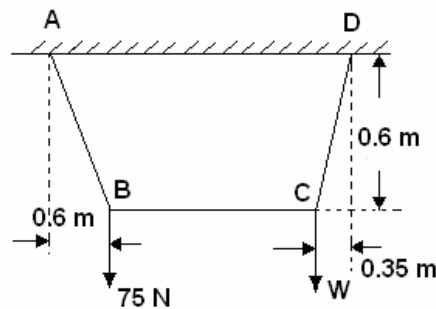

Fig: 1

- 2.a) Define free body diagram. Give 4 examples.
- b) Forces are applied to an angle bracket as shown in figure 2. Determine the magnitude and direction of the resultant.

[6+10]

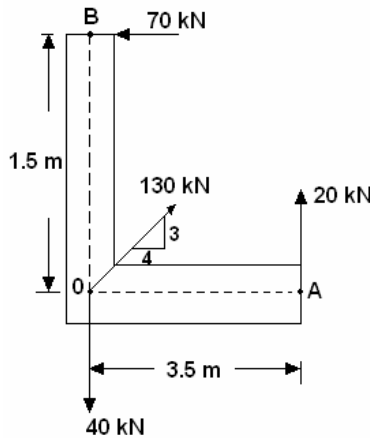

Fig: 2

- 3.a) Distinguish between centroid and centre of gravity.
- b) Find the coordinates of the centroid of the shaded area shown in figure 3. [4+12]

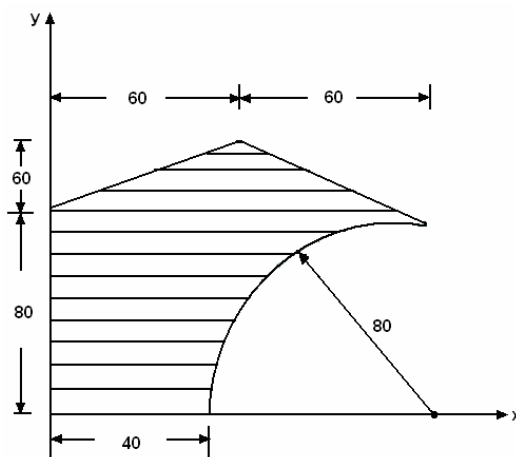

Fig: 3

- 4.a) What are the transfer formula for mass moments of inertia?
 b) Compute the moment of inertia of the channel section shown in figure 4 about centroidal x, y axes. [4+12]

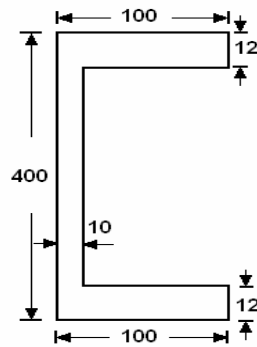

Fig: 4

- 5.a) Sketch the various types of trusses.
 b) Find the forces in the members BD, DE, EG and BE of the truss shown in figure 5. [4+12]

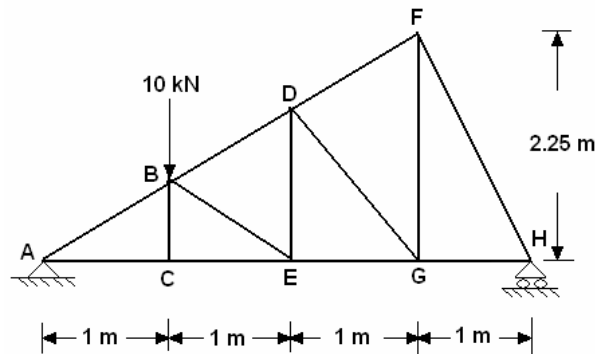

Fig: 5

- 6.a) State and explain D' Alembert's principle.
 b) A stone is thrown from the top of a building upward at an angle of 40° to the horizontal with an initial speed of 30 m/sec. The height of the building is 30 m. Determine:
 i) The horizontal distance from the point of projection to the point where the stone strikes the ground.
 ii) The greatest elevation reached by the stone
 iii) Velocity, when it strikes the ground
 iv) Time of flight. [4+12]

- 7.a) State and explain impulse-momentum principle.
 b) Determine the time required for the heights shown in figure 6 to attain a velocity of 9.81 m/sec. What is the tension in the chord? Take $\mu = 0.2$ for both planes. [4+12]

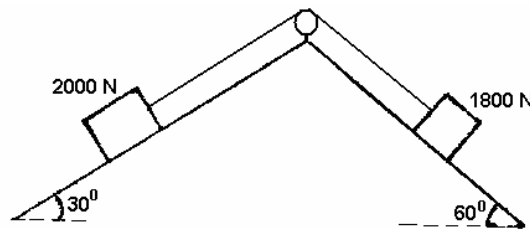

Fig: 6

- 8.a) Define the terms:
 i) Time period ii) Free vibration iii) Damping.
 b) A particle performing SHM has a frequency of 12 oscillations/minute at a distance 10 cm from the mean position, its velocity is 0.5 times of the maximum velocity. Find:
 i) The amplitude of oscillation
 ii) Maximum acceleration
 iii) Velocity of the particle, when it is at a distance of 6 cm from the mean position. [6+10]

* * * * *

I B.TECH - EXAMINATIONS - MAY, 2011
CLASSICAL MECHANICS
 (COMMON TO MECHANICAL ENGINEERING, CHEMICAL ENGINEERING &
 MECHATRONICS)

Time: 3hours

Max. Marks: 80

Answer any FIVE questions
All Questions Carry Equal Marks

- - -

- 1.a) Distinguish between centroid and centre of gravity.
 b) Find the coordinates of the centroid of the shaded area shown in figure 1. [4+12]

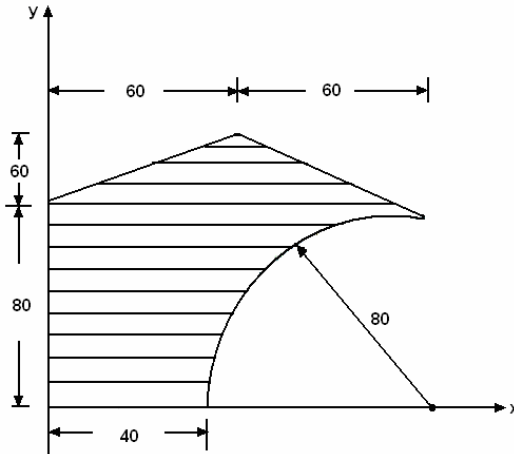

Fig: 1

- 2.a) What are the transfer formula for mass moments of inertia?
 b) Compute the moment of inertia of the channel section shown in figure 2 about centroidal x, y axes. [4+12]

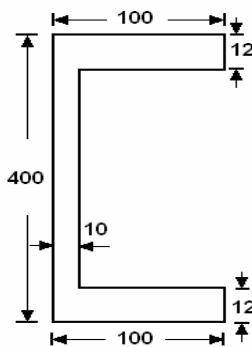

Fig: 2

- 3.a) Sketch the various types of trusses.
 b) Find the forces in the members BD, DE, EG and BE of the truss shown in figure 3. [4+12]

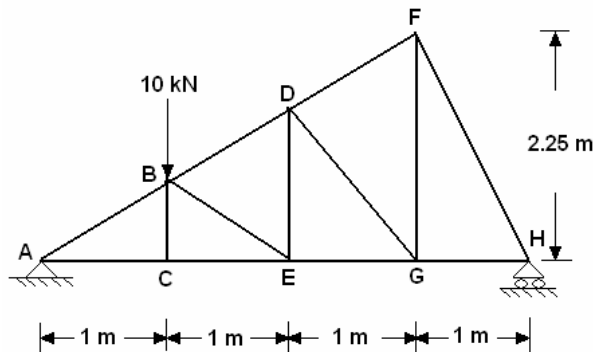

Fig:3

- 4.a) State and explain D' Alembert's principle.
 b) A stone is thrown from the top of a building upward at an angle of 40° to the horizontal with an initial speed of 30 m/sec. The height of the building is 30 m. Determine:
 i) The horizontal distance from the point of projection to the point where the stone strikes the ground.
 ii) The greatest elevation reached by the stone
 iii) Velocity, when it strikes the ground
 iv) Time of flight. [4+12]

- 5.a) State and explain impulse-momentum principle.
 b) Determine the time required for the heights shown in figure 5 to attain a velocity of 9.81 m/sec. What is the tension in the chord? Take $\mu = 0.2$ for both planes.

[4+12]

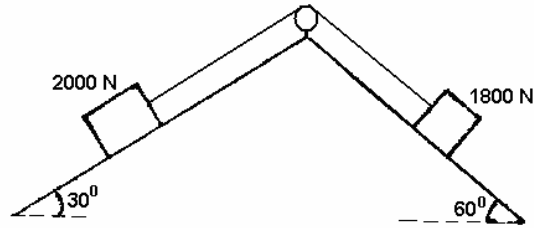

Fig: 5

- 6..a) Define the terms:
 i) Time period ii) Free vibration iii) Damping.
 b) A particle performing SHM has a frequency of 12 oscillations/minute at a distance 10 cm from the mean position, its velocity is 0.5 times of the maximum velocity. Find:

- i) The amplitude of oscillation
 ii) Maximum acceleration
 iii) Velocity of the particle, when it is at a distance of 6 cm from the mean position.

[6+10]

- 7.a) Distinguish between co-planar and non-co planar forces. Classify the various types of forces.
 b) AD is a string hung from a horizontal ceiling at A and D. A weight of 75 N is hung from point B. Determine the magnitude of weight that should be hung from point C such that the portion BC of the string is horizontal. Also determine the tension in various portions AB, BC and CD of the string as shown in figure 7.

[6+10]

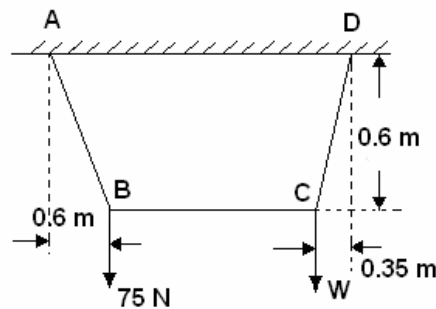

Fig: 7

- 8.a) Define free body diagram. Give 4 examples.
 b) Forces are applied to an angle bracket as shown in figure 8. Determine the magnitude and direction of the resultant.

[6+10]

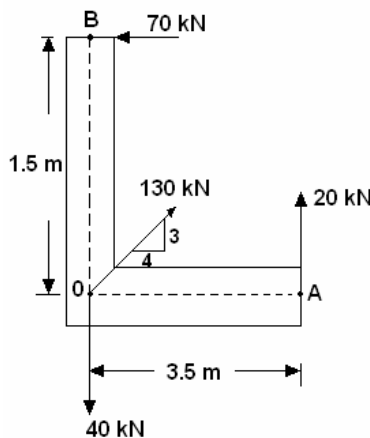

Fig: 8

* * * * *

I B.TECH - EXAMINATIONS - MAY, 2011
CLASSICAL MECHANICS
 (COMMON TO MECHANICAL ENGINEERING, CHEMICAL ENGINEERING &
 MECHATRONICS)

Time: 3hours

Max. Marks: 80

Answer any FIVE questions
 All Questions Carry Equal Marks

- - -

- 1.a) Sketch the various types of trusses.
 b) Find the forces in the members BD, DE, EG and BE of the truss shown in figure 1. [4+12]

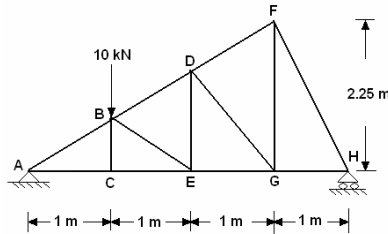

Fig: 1

- 2.a) State and explain D' Alembert's principle.
 b) A stone is thrown from the top of a building upward at an angle of 40° to the horizontal with an initial speed of 30 m/sec. The height of the building is 30 m. Determine:
 i) The horizontal distance from the point of projection to the point where the stone strikes the ground.
 ii) The greatest elevation reached by the stone
 iii) Velocity, when it strikes the ground
 iv) Time of flight. [4+12]

- 3.a) State and explain impulse-momentum principle.
 b) Determine the time required for the heights shown in figure 3 to attain a velocity of 9.81 m/sec. What is the tension in the chord? Take $\mu = 0.2$ for both planes. [4+12]

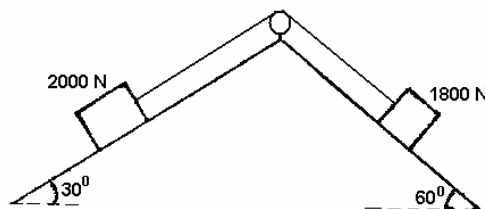

Fig: 3

- 4..a) Define the terms:
 i) Time period ii) Free vibration iii) Damping.
 b) A particle performing SHM has a frequency of 12 oscillations/minute at a distance 10 cm from the mean position, its velocity is 0.5 times of the maximum velocity. Find:
 i) The amplitude of oscillation
 ii) Maximum acceleration
 iii) Velocity of the particle, when it is at a distance of 6 cm from the mean position. [6+10]

- 5.a) Distinguish between co-planar and non-co planar forces. Classify the various types of forces.
 b) AD is a string hung from a horizontal ceiling at A and D. A weight of 75 N is hung from point B. Determine the magnitude of weight that should be hung from point C such that the portion BC of the string is horizontal. Also determine the tension in various portions AB, BC and CD of the string as shown in figure 5. [6+10]

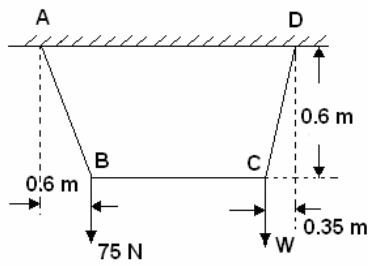

Fig: 5

- 6.a) Define free body diagram. Give 4 examples.
 b) Forces are applied to an angle bracket as shown in figure 6. Determine the magnitude and direction of the resultant. [6+10]

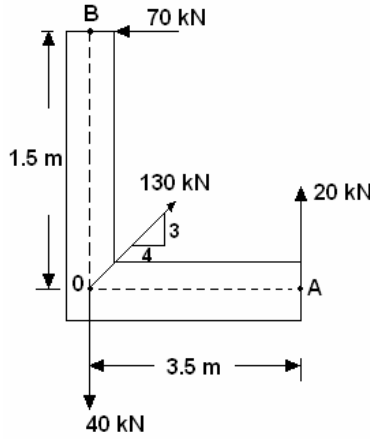

Fig: 6

- 7.a) Distinguish between centroid and centre of gravity.
 b) Find the coordinates of the centroid of the shaded area shown in figure 7. [4+12]

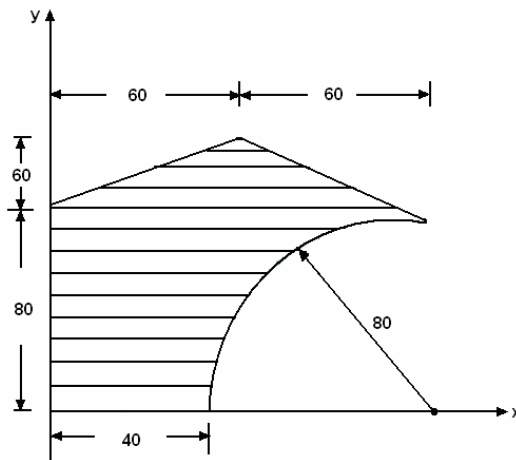

Fig: 7

- 8.a) What are the transfer formula for mass moments of inertia?
 b) Compute the moment of inertia of the channel section shown in figure 8 about centroidal x, y axes. [4+12]

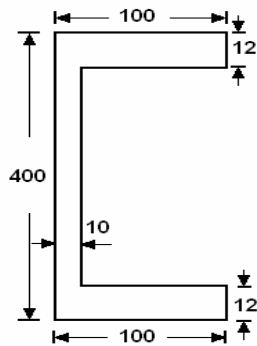

Fig: 8

* * * * *

I B.TECH - EXAMINATIONS - MAY, 2011
CLASSICAL MECHANICS
 (COMMON TO MECHANICAL ENGINEERING, CHEMICAL ENGINEERING &
 MECHATRONICS)

Time: 3hours

Max. Marks: 80

Answer any FIVE questions
 All Questions Carry Equal Marks

- - -

- 1.a) State and explain impulse-momentum principle.
 b) Determine the time required for the heights shown in figure 1 to attain a velocity of 9.81 m/sec. What is the tension in the chord? Take $\mu = 0.2$ for both planes.

[4+12]

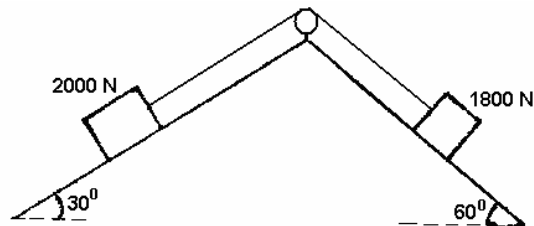

Fig: 1

- 2..a) Define the terms:
 i) Time period ii) Free vibration iii) Damping.
 b) A particle performing SHM has a frequency of 12 oscillations/minute at a distance 10 cm from the mean position, its velocity is 0.5 times of the maximum velocity.

Find:

- i) The amplitude of oscillation
 ii) Maximum acceleration
 iii) Velocity of the particle, when it is at a distance of 6 cm from the mean position. [6+10]
 3.a) Distinguish between co-planar and non-co planar forces. Classify the various types of forces.
 b) AD is a string hung from a horizontal ceiling at A and D. A weight of 75 N is hung from point B. Determine the magnitude of weight that should be hung from point C such that the portion BC of the string is horizontal. Also determine the tension in various portions AB, BC and CD of the string as shown in figure 3.

[6+10]

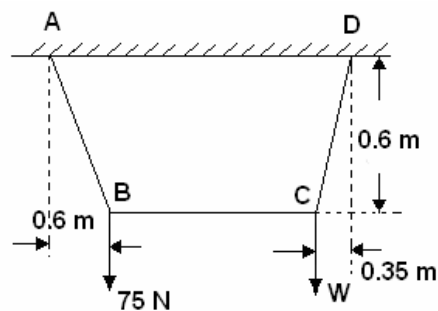

Fig: 3

- 4.a) Define free body diagram. Give 4 examples.
 b) Forces are applied to an angle bracket as shown in figure 4. Determine the magnitude and direction of the resultant. [6+10]

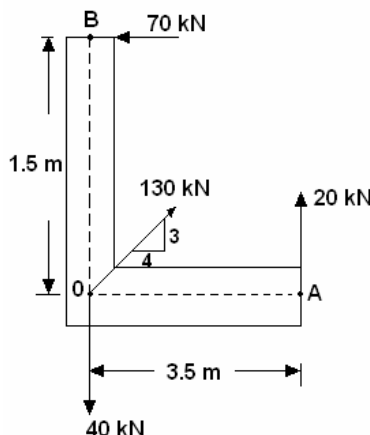

Fig: 4

- 5.a) Distinguish between centroid and centre of gravity.
 b) Find the coordinates of the centroid of the shaded area shown in figure 5. [4+12]

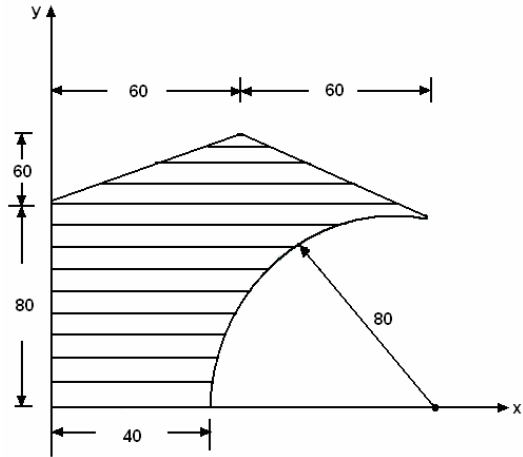

Fig: 5

- 6.a) What are the transfer formula for mass moments of inertia?
 b) Compute the moment of inertia of the channel section shown in figure 6 about centroidal x, y axes. [4+12]

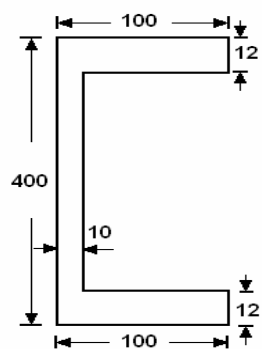

Fig: 6

- 7.a) Sketch the various types of trusses.
 b) Find the forces in the members BD, DE, EG and BE of the truss shown in figure 7. [4+12]

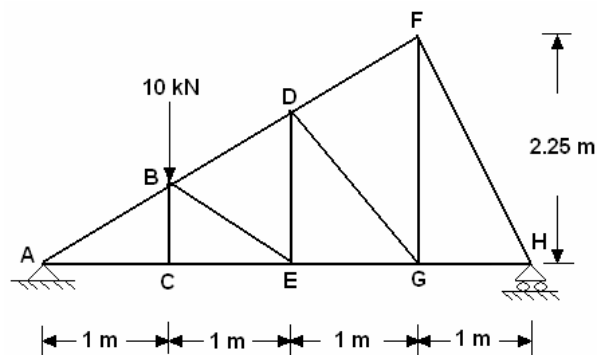

Fig: 7

- 8.a) State and explain D' Alembert's principle.
 b) A stone is thrown from the top of a building upward at an angle of 40° to the horizontal with an initial speed of 30 m/sec. The height of the building is 30 m. Determine:
 i) The horizontal distance from the point of projection to the point where the stone strikes the ground.
 ii) The greatest elevation reached by the stone
 iii) Velocity, when it strikes the ground
 iv) Time of flight. [4+12]

* * * * *